

RICH CONFIGURATIONS

Standard parts

Fingertip armrest
LED light
Guiding laser
80V battery
80V AC ZAPI controller
80V AC lifting&driving motor
Waterproof cable
Back up Alarm
OPS system
Integrated side-shift
Black solid tire
Adjustable suspension seat

Optional parts

Non-marking solid tyre
Height preselector
Wireless camera(6650-10050mm)
Dual camera
Hydraulic double-deep forks

NALiFT

Narrower Aisle-Less Cost-Higher Productivity



NALiFT

Europe Nalift Co., Ltd
Add: 1 Dock Road, London, E16 1AH
Tel: +86-551-67330559
+86-551-67330557
Fax: +86-551-67330558
Web: www.nalift.cn

AC Electric VNA Forklift



BACKGROUND



Europe Nalift Co., Ltd is a British company specializing in the production of articulated forklifts. The founder is a technical director with 40 years of experience in design and manufacturing in the narrow-aisle forklift industry. He has built the NALIFT brand by combining his years of accumulated experience and upgrading and innovation based on the original technology.

The core components of Nalift are all derived from Europe and are assembled in China. Since its inception, Nalift has always been known for its high cost performance and at the same time providing the best service to its customers.

We have advanced production lines, complete research and development equipment and quality service to provide customers with first-class product experience. After scientific testing and high-intensity driving test, Nalift products can achieve higher lifting height, greater bearing capacity, better handling experience and lower operating costs, which not only improves production efficiency but also saves warehouse space.

To store more in less space at a lower cost



Nalift is a professional manufacturer of very narrow aisle material handling equipment, offering high quality VNA forklift, our products provide the lowest cost of ownership while maximizing space and productivity to benefit our clients.

Nalift trucks are tough, versatile and built to last. designed to withstand heavy-duty use Inside and outside, each VNA articulated truck Is manufactured to high standard and honored with ISO9001, CE, SGS certificate and special equipment manufacturing license.

This innovative design brings a lot of convenience to customers, including higher lift height, narrower warehouse access, higher work efficiency, better driving experience and lower operating costs. All the work of counterbalanced and reach forklifts can be done by only one NALIFT articulated forklift.

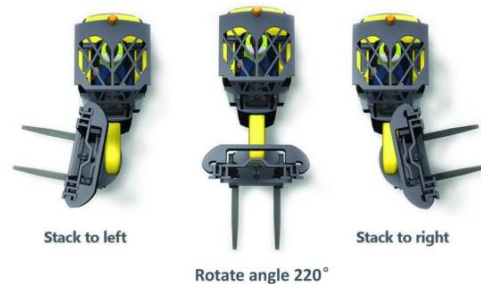

Strong, versatile, flexible, enlarge warehouse and save costs

- Lift height up to 10m, aisle width as narrow as 1.9m.
- NALIFT stores 50% more pallet positions than counterbalance forklifts and 30% more pallet positions than reach trucks.
- 220° articulated angle, flexible working in the ultra-narrow channel
- 80V AC controller, low heating, low error.
- 80V AC lifting&driving motor, maintenance free, strong power, high efficiency.
- Electro-hydraulic proportional valve, valve speed can be adjusted according to the will, making it easier and more accurate to pick up/unload goods.
- Fingertip control provides better control experience, more flexible and accurate operation. Providing special picking mode, easy to operate. With better micro performance, it is very suitable for high lifting conditions.
- Firm construction of chassis and mast ensure heavy-duty use.
- NALIFT can operate on any floor surface, both inside and out, eliminates double handling, move pallet from lorry to rack in one step, so it save much time and money.
- The maintenance cost is significantly less than complicated reach trucks/swing reach truck.
- Local dealer support and engineer services.

RICH CONFIGURATIONS



Wireless camera provides better sight



Adjustable suspension seat
OPS system



80V AC electric lifting motor
external encoder



80V AC electric driving motor
external encoder



Easy battery change
water supply subsystem



Fingertip armrest provides more comfortable
and accurate operation experience



The panel displays error codes



Shock-absorbing solid tyre



80V AC electric controller
independently control each part



Electro-hydraulic mul-tiway valve
provides better inching performance

LOAD CHART AND LAYOUT CONTRAST

220° Rotate Angle+50% Extra Space

1. Aisle width as narrow as 1900mm (Pallet size 1000x1200mm)
2. Nalift stores 30% more pallets than reach truck.
3. Nalift stores 50% more pallets than counterbalanced forklift.
4. All the work of counterbalanced and reach forklifts can be done by only one NALIFT articulated forklift.
5. Increase storage and reduce warehouse cost

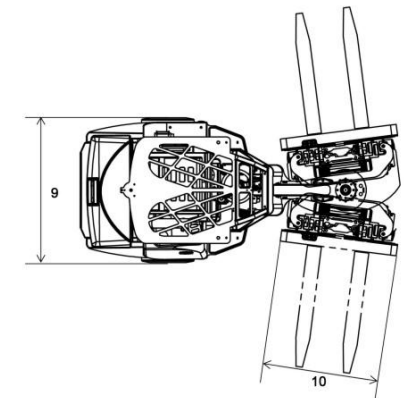
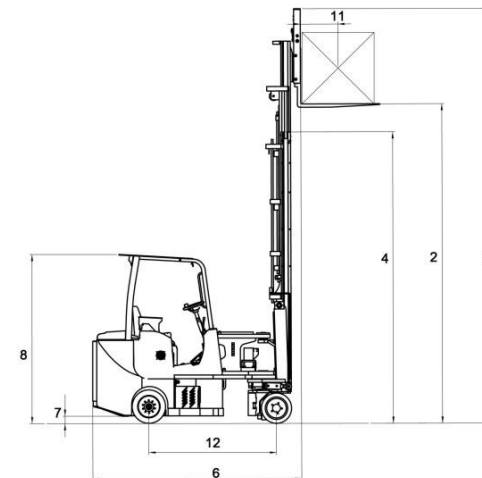
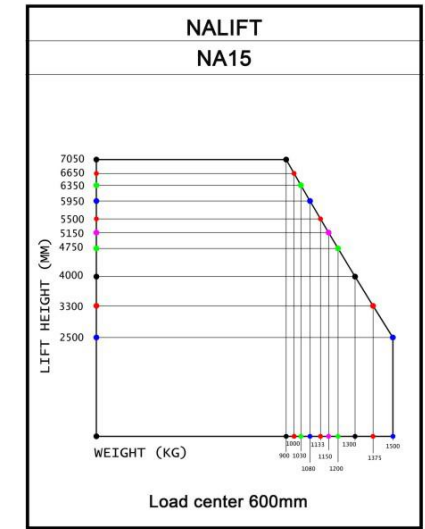
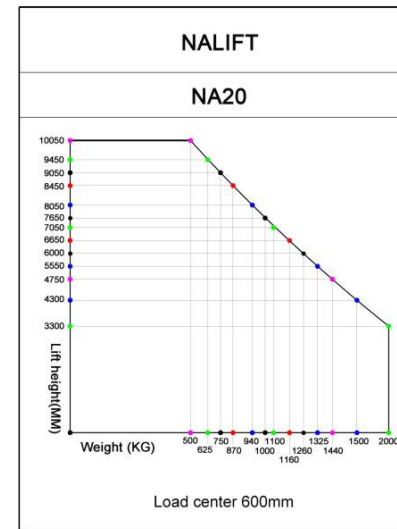
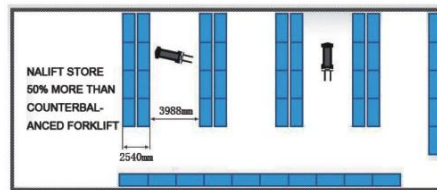
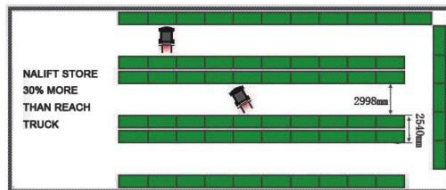
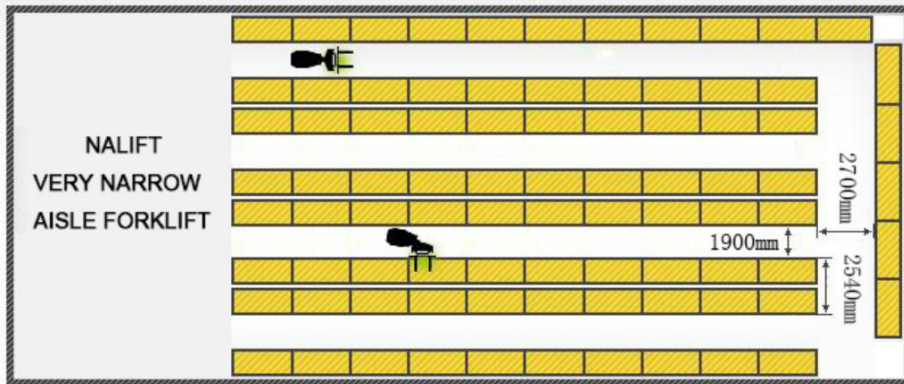

TECHNICAL DATA

	Model	Unit	NA15	NA20
1	Capacity	KG	1500	2000
2	Lift height	MM	6650	9450
3	Free lift	MM	2215	3435
4	Mast closed height	MM	3115	4315
5	Mast extended height	MM	7911	10691
6	Overall length	MM	2780	
7	Ground clearance	MM	50	
8	Overhead guard height	MM	2270	
9	Chassis width rear	MM	1030	1270
10	Chassis width front	MM	980	
11	Load center	MM	600	
12	Wheel base	MM	1745	
13	Seat height	MM	1220	
14	Mast tilt(fwd/back)	°	1°/3°	
15	Mast rotate angle (left/right)	°	220	
16	Ground speed	Km/h	16	
17	Lift speed(load/unload)	m/s	0.44/0.5	
18	Front tyre size	MM	412x174	
19	Rear tyre size	MM	457x150	
20	Grade ability(load/unload)	%	18/20%	
21	Battery voltage/capacity	V/AH	80/400	80/500
22	Weight of truck excluding battery	KG	5150	5310
23	Weight of truck including battery	KG	6400	6900
24	Traction motor	AC	19.5 KW	
25	Lifting motor	AC	15KW	
26	Aisle width	mm	1900	